

FALF-152DL 干法工艺



产品介绍 Introduction

福斯特FALF-152DL采用特殊的干法工艺制程，使产品具有稳定的复合强度，优良的耐电解液性能和成型性，产品轻薄，尤其适用于电动汽车EV/HEV、电动自行车、电动工具、通讯站、储能电池等锂电池的软包设计。



产品结构 Structure

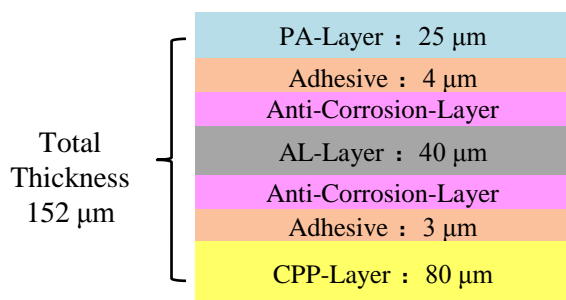

产品性能 Properties

项目 Item	单位 Unit	性能指标 Typical Values		检测方法 Test Method
		MD	TD	
PA/AL层间剥离强度 PA/AL Peel Strength	N/15mm	MD	≥4	180° 50mm/min
		TD	≥4	
AL/ CPP层间剥离强度 AL/ CPP Peel Strength	N/15mm	MD	≥18	GB 8808-88 T型 300mm/min
		TD	≥18	
热封强度 Sealing Strength	N/15mm	≥50		QB/T 2358-1998 190°C 0.5 MPa 3 s
二封边热封强度 Electrolyte Sealing Strength	N/15mm	≥40		QB/T 2358-1998 190°C 0.5 MPa 3 s
成型性能 Formability	mm	≥5.5		模具尺寸 39.2 mm*33.3 mm*2
耐电解液性能 Electrolyte Resistance	N/15mm	≥4		EC/DEC/DMC=1/1/1 1 mol LiPF ₆ 85°C 14 d
卤素检测 Halogen Detection		SGS报告		合格
RoHS检测 RoHS Substances Test		SGS报告		合格

FALF-152DL 性能指标



一 冲深模具及冲深性能 Drawability Mold and Performance

- 模具水平垂直 R = 1.5 mm
Mold Horizontal Vertical
- 模具表面粗糙度 5 μm
Mold Surface Roughness
- 模具间隙 2.2 mm
Mold Gap

39.2mm*33.3mm*2	
冲深深度 Drawability Depth	5.0 mm
AL 残存率 AL Residual Rate	≥50%

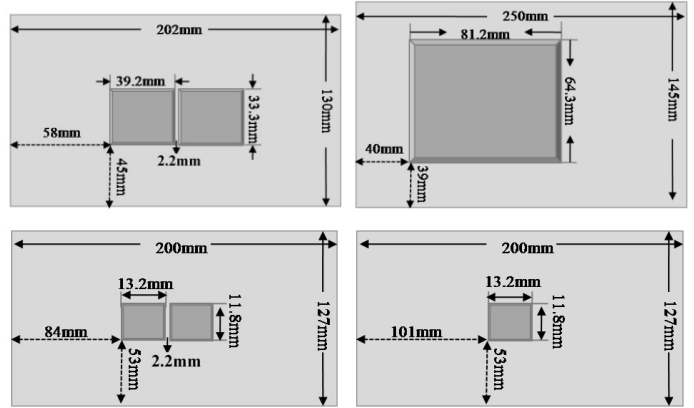

二 耐电解液的使用安全性评估 Safety Using Assessment of Electrolyte Resistance

- 样品尺寸：
15 mm*100 mm 试样条
- 电解液：
EC/DEC/DMC=1/1/1+1 mol LiPF₆
- 测试方法：
将上述尺寸样品浸泡在85°C 电解液中不同天数，样品洗净后，300 mm/min T型剥离测定AL/PP层间剥离强度。

85°C 电解液中浸泡不同天数后层间剥离强度

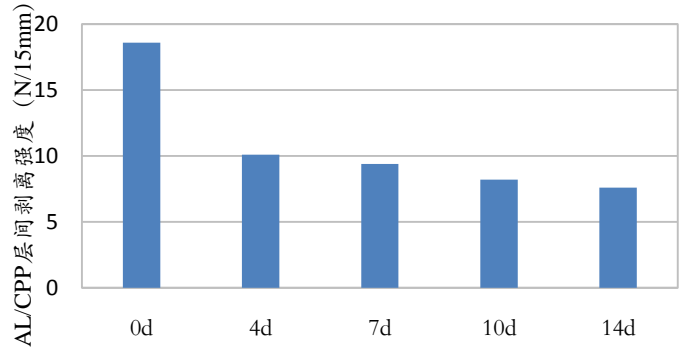

85°C 电解液中浸泡14天也可保持 4 N/15mm 以上的层间剥离强度

三 热封性能 Heat Sealing Performance

热封强度与热封温度关系曲线

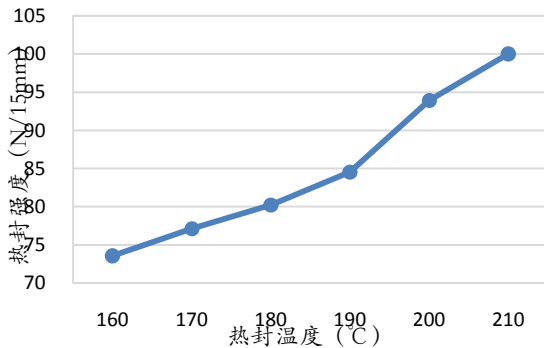

热封压力：0.5 MPa 热封时间：3 s

四 绝缘性能 Insulation Performance

铜极耳与铝箔间电阻值

原样品	60°C-95%RH/1 W
>20 MΩ	>20 MΩ

